

## The history of wastewater treatment in the 20<sup>th</sup> century in Helsinki

Mikko Nissinen

### Period before 1930

At the end of the 19<sup>th</sup> century and in the first decade of the 20<sup>th</sup> century, wastewater was discharged via sewers straight into the sea. As a result shore waters became polluted.

In order to protect urban water courses wastewater treatment plants were constructed in the centre of Helsinki in the district of Alppila in 1910 and in Savila in 1915. They were equipped with septic tanks and trickling filters. The Alppila plant was rebuilt in 1927, when double settling tanks and a biological filter were introduced.

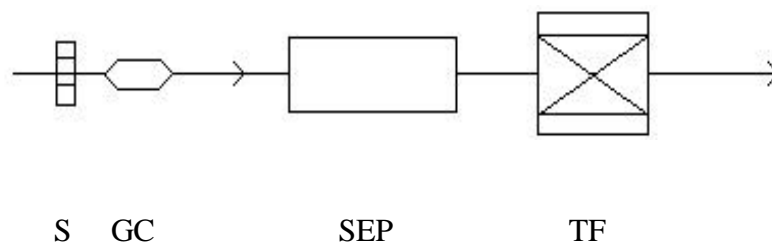

Figure 1. The wastewater treatment process of the Alppila plant in 1910: screen (S), grit chamber (GC), septic tank (SEP), trickling filters (TF).

## Period 1930-1950

The first activated sludge wastewater treatment plant (Kyläsaari) was taken into operation in 1932. The incoming wastewater passed through screens and a sand remover. This plant had four separate parallel lines which made it possible to research wastewater purification processes and results.

The second plant (Rajasaari) was completed in 1936 and its technology was similar to that of the Kyläsaari plant. In this plant sludge was separated, digested and transformed into gas and dry sludge. The gas produced was used in power generation and the dry sludge was used for agricultural purposes. In 1950 the capacity of these plants was approximately 10 million m<sup>3</sup>.

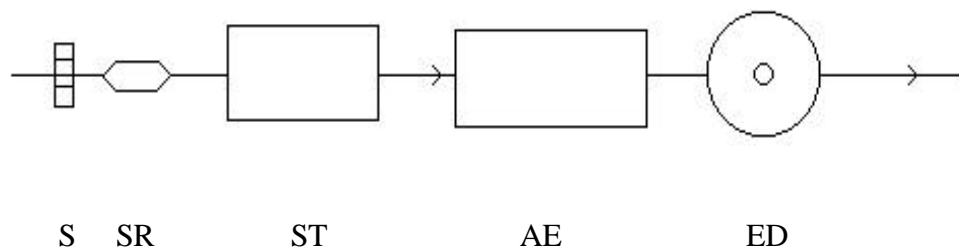

Figure 2. Wastewater treatment process at the Kyläsaari and Rajasaari plants: screen (S), sand remover (SR), aeration tank (AE), and Emscher dwell (ED).

## Period 1950-1970

As the population and wastewater volume grew, new wastewater treatment plants were built. They were based on mechanical purification and an activated sludge method.

The first plant built after the Second World War was in Tali. When it was first operational in 1957 this modern treatment plant functioned properly, but as the volume increased, problems occurred with the treatment process. The wastewater did not clarify properly, as a down pipe in the post-clarification pool caused turbulence. This problem was solved in the 1960s.

The next plant was built in Herttoniemi in 1958 and it was extended twice. However, it was soon noticed that the new structures applied were not always more effective than the old ones. This plant served as an example for several other plants. The Kulosaari plant was completed in 1960 and the Lauttasaari plant in 1962. These two plants experienced problems as soon as they began operating. The round shape of the Kulosaari plant caused turbulence problems in clarification: turbulence started in aeration and continued in the post-clarification pool, thus disturbing clarification. In the Lauttasaari plant currents in pools caused problems because the connection between aeration and preclarification pools was too wide. After some technical adjustments these plants operated satisfactorily.

The Viikki treatment plant was taken into operation in 1963. It was similar to the Lauttasaari plant except the connection between aeration and postclarification pools was not as wide as in the former plant.

The Munkkisaari treatment plant was completed in 1967. It was built in a basement of an old warehouse and was thus the first indoor plant. Postclarification was done using the same technology as in the improved Kulosaari plant, and its performance was satisfactory.

The Laajasalo treatment plant began operating in 1966. This plant was a "rapid block" model. It did not operate well in the beginning, but in time the purification results improved after experimenting with new equipment.

In 1970 the total volume of wastewater treated in these plants was approximately 50 million m<sup>3</sup>.

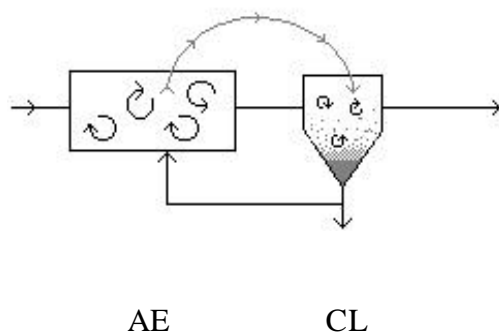

Figure 3. The problematic Kulosaari plant. Turbulence started in aeration (AE) and continued in clarification (CL).

## Period 1970-1994

During this period the only one new 'treatment plant' was build in Vuosaari in 1971. It was a man-made pond where wastewater was dumped and a natural treatment process applied. A mechanical device was installed to improve the aeration in the pond, but it was uncertain if it had any positive effect.

In the 1970s phosphorus removal with  $\text{FeSO}_4$  precipitation was introduced.

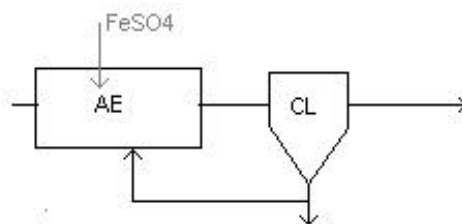

Figure 4. Method for simultaneous precipitation: aeration (AE), clarification (CL).

## Period 1994 to present

A new period in wastewater treatment started in 1994 when the Viikinmäki plant, excavated inside a rock, was taken into operation. This plant treats the industrial wastewater and wastewater of almost one million inhabitants. It has replaced all existing treatment plants in Helsinki.

The basic treatment method is the activated sludge method. The process consists of three phases: mechanical, biological and chemical purification. Solids, organic matter and 95% of phosphorus are removed from wastewater, as well as more than 50% of nitrogen. In 1998 approximately 100 million m<sup>3</sup> of wastewater were treated in the Viikinmäki plant.

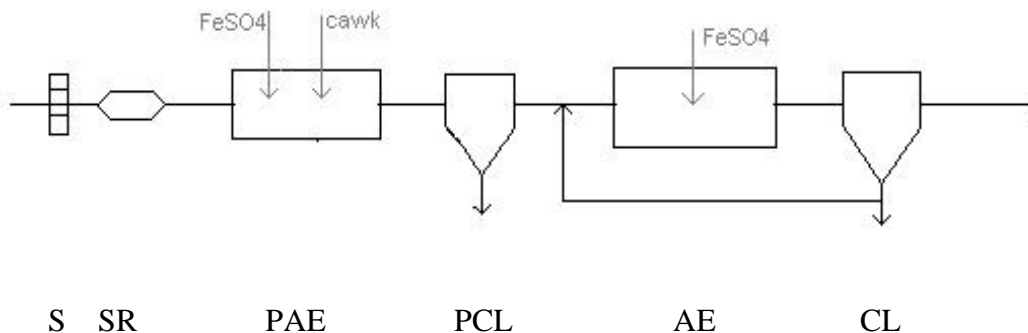

Figure 5. The wastewater treatment process in the Viikinmäki plant: screen (S), sand remover (SR), preaeration (PAE), preclarification (PCL), aeration (AE), clarification (CL).